

**BCS THE CHARTERED INSTITUTE FOR IT**  
**BCS HIGHER EDUCATION QUALIFICATIONS**  
**BCS Level 4 Certificate in IT**

**COMPUTER & NETWORK TECHNOLOGY**

Thursday 23<sup>rd</sup> March 2017 – Morning  
Time: TWO hours

Section A and Section B each carry 50% of the marks.  
You are advised to spend about 1 hour on Section A (30 minutes per question)  
and 1 hour on Section B (12 minutes per question).

**Answer any Section A questions you attempt in Answer Book A**  
**Answer any Section B questions you attempt in Answer Book B**

The marks given in brackets are **indicative** of the weight given to each part of the question.

Calculators are <b>NOT</b> allowed in this examination.
---

**Section A**

**Answer 2 questions (out of 4). Each question carries 30 marks.**

**A1**

- a) Malicious (harmful) programs called **malware** have been designed to interfere with the correct running of a computer. Explain what malware is, and give three examples of different classes of malware.  

**(20 marks)**
- b) What can the user do to minimize the effects of malware? Your answer should include a short discussion of the difference between the steps taken by the individual (home) user and the commercial (professional) user.  

**(10 marks)**

**A2**

- a) Digital systems use two different classes of logic element: **combinational** and **sequential**. What is the difference between these two types of logic element? You need only give a short definition.  

**(4 marks)**
- b) Name **THREE** types of combinational logic element and **THREE** types of sequential logic element.  

**(6 marks)**
- c) What is an exclusive OR gate (also called an EOR, or XOR gate)? Provide a truth table for an exclusive OR gate and explain in plain English what it does.  

**(5 marks)**
- d) For the circuit below, draw a truth table and provide the values of the outputs at points P, Q, R, S, and T.  

**(10 marks)**

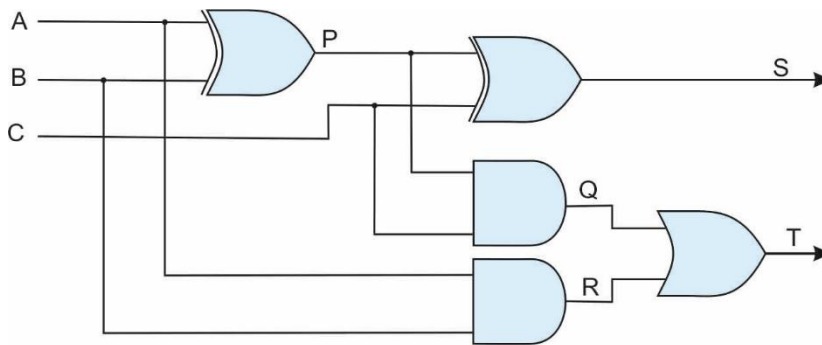

- e) Examine the relationship between inputs A, B, C and outputs S and T. Explain what this circuit achieves and how it is used in digital systems.

**(5 marks)**

### A3

Two technologies have been applied to the design of all modern high-performance computers in order to improve their performance; **cache memory** technology and **virtual memory** technology.

- a) Explain the meaning of cache memory and describe how it contributes to the performance of a computer. Your answer should include a discussion of the nature of cache memory, why it is used, and why so little cache memory is required to significantly enhance the performance of a computer.

**(10 marks)**

- b) A computer has a cache memory with an average **hit rate** of 0.85. If the cache memory has an access time of 5 ns and the DRAM has an access time of 70 ns, what is the average memory access time of this system?

**(5 marks)**

- c) Explain the meaning of **virtual memory** and explain how it contributes to the performance of a modern computer system. Your answer should include a discussion of memory management which is used to implement a virtual memory system.

**(15 marks)**

### A4

It is possible to send an email from your home computer to a friend who lives in a country several thousand kilometres away.

Explain how the communication is made between your computer and the remote computer. Your answer should describe the communications equipment involved in the data exchange (e.g., modem, router), and the type of physical data links across which the information may flow.

**(30 marks)**

## Section B

Answer 5 questions (out of 8). Each question carries 12 marks.

### B5

Storage in computer systems is essential. Using examples of their use, briefly explain:

- a) Cloud storage (6 marks)
- b) Disk storage (6 marks)

### B6

Describe the architecture and use of the following types of computer networks:

- a) LAN (4 marks)
- b) WAN (4 marks)
- c) VPN (4 marks)

### B7

As a computer technician, you have been asked to provide advice on a range of computers and devices. Briefly describe and differentiate between:

- a) Desktop computers (4 marks)
- b) Laptop computers (4 marks)
- c) Tablets (4 marks)

### B8

Briefly describe the following Operating Systems functions:

- a) Memory management (4 marks)
- b) File management (4 marks)
- c) Control over system performance (4 marks)

### B9

Briefly describe the following devices/terms

- a) Scanner (3 marks)
- b) Laser printer (3 marks)
- c) Touch screen (3 marks)
- d) VoIP (3 marks)

### B10

- a) Explain why organisations need to backup their data. (6 marks)
- b) Describe briefly THREE methods of data backup. (6 marks)

**B11**

Explain the purpose of the following registers:

- a) MAR (4 marks)
- b) MBR (4 marks)
- c) Program Counter (4 marks)

**B12**

Briefly describe the seven layers of the OSI Model. (12 marks)